

EDMS 722

Assignment 2: SOLUTIONS

1. As defined in class and in the readings, which elements (variables and errors) in the above model are exogenous and which are endogenous?

Exogenous: V1, V2, E3, E4

Endogenous: V3, V4

2. Write out the structural equations associated with this theoretical model. Use the path labels as they appear in the original diagram above, but use the V variable labels for the variable names. Be sure to include the errors in your equations where appropriate.

$$V3 = b_{31}V1 + E3$$

$$V4 = b_{43}V3 + b_{42}V2 + E4$$

3. COVARIANCES

σ_{21}	=	c_{12} nonstructural relation (unanalyzed)		
σ_{31}	=	$b_{31} c_{V1}$ direct effect		
σ_{32}	=	$b_{31} c_{12}$ nonstructural relation		
σ_{41}	=	$b_{43} b_{31} c_{V1}$ indirect effect	+	$b_{42} c_{12}$ nonstructural relation (unanalyzed)
σ_{42}	=	$b_{42} c_{V2}$ direct effect	+	$b_{31} b_{43} c_{12}$ nonstructural relation (unanalyzed)
σ_{43}	=	$b_{43} c_{V3}$ direct effect	+	$b_{31} c_{12} b_{42}$ nonstructural relation (unanalyzed)

VARIANCES

$$\begin{aligned} \sigma_1^2 &= c_{V1} \\ \sigma_2^2 &= c_{V2} \\ \sigma_3^2 &= (b_{31})^2 c_{V1} + c_{E3} \\ \sigma_4^2 &= (b_{43})^2 c_{V3} + (b_{42})^2 c_{V2} + 2 b_{42} c_{12} b_{31} b_{43} + c_{E4} \end{aligned}$$

4. a.

$$\begin{aligned} \sigma_{43} &= b_{43} [(b_{31})^2 c_{V1} + c_{E3}] + b_{31} c_{12} b_{42} \\ \sigma_4^2 &= (b_{43})^2 [(b_{31})^2 c_{V1} + c_{E3}] + (b_{42})^2 c_{V2} + 2 b_{42} c_{12} b_{31} b_{43} + c_{E4} \end{aligned}$$

- b. Eight different parameters must be solved for:

direct paths: b_{31}, b_{43}, b_{42}

modeled covariances: c_{12}

exogenous variances: $c_{V1}, c_{V2}, c_{E3}, c_{E4}$

$$\begin{aligned}
5. \quad 6.840 &= c_{12} \\
5.658 &= b_{31} c_{V1} \\
22.374 &= b_{31} c_{12} \\
0.346 &= b_{43} b_{31} c_{V1} &+ & b_{42} c_{12} \\
6.065 &= b_{42} c_{V2} &+ & b_{31} b_{43} c_{12} \\
3.220 &= b_{43} [(b_{31})^2 c_{V1} + c_{E3}] + b_{31} c_{12} b_{42} \\
2.250 &= c_{V1} \\
231.040 &= c_{V2} \\
84.640 &= (b_{31})^2 c_{V1} + c_{E3} \\
0.490 &= (b_{43})^2 [(b_{31})^2 c_{V1} + c_{E3}] + (b_{42})^2 c_{V2} + 2 b_{42} c_{12} b_{31} b_{43} + c_{E4}
\end{aligned}$$

6. How many "pieces of information" (unique variances and covariances, u) are in the sample variance/covariance matrix? How many population parameters in total (t) need to be estimated? Assuming that the model can be solved, does this model appear to be under-, just-, or over-identified? Explain.

$$u = 4(4+1)/2 = 10 \text{ pieces of information}$$

$$t = 8 \text{ parameters}$$

If parameters are estimable, the model should be over-identified with 2 degrees of freedom.

7. Based on your output, write the unstandardized solutions for each of the population parameters to be estimated: direct paths, variances of exogenous elements (variables and errors), and covariances among exogenous elements.

$$\text{direct paths: } b_{31}=2.51, b_{43}=0.032, b_{42}=0.023$$

$$\text{modeled covariances: } c_{12}=6.84$$

$$\text{exogenous variances: } c_{V1}=2.25, c_{V2}=231.04, c_{E3}=70.41, c_{E4}=0.25$$

$$\begin{aligned}
8. \quad \sigma_{41} &= b_{43} b_{31} c_{V1} + b_{42} c_{12} \\
\sigma_{41} &= (.032)(2.51)(2.25) + (.023)(6.84) \\
\sigma_{41} &= .338 \text{ (SIMPLIS reports .34, rounded to 2 decimals)}
\end{aligned}$$

9. a. Using criteria discussed in class, what do you conclude about the overall fit of this model based on its goodness of fit summary information? Explain.

Below are some preferred indices, all of which indicates very favorable data-model fit individually or taken jointly as per the guidelines of Hu & Bentler (1999):

$$\begin{aligned}
\text{Root Mean Square Error of Approximation (RMSEA)} &= 0.0 \\
\text{Comparative Fit Index (CFI)} &= 1.00 \\
\text{Standardized RMR} &= 0.015
\end{aligned}$$

b. Using the equation given in class, derive the value for the Comparative Fit Index based on the independence model χ^2 ("Chi-Square for Independence Model") and the theoretical model χ^2 ("Minimum Fit Function Chi-Square") information.

$$CFI = 1 - \max(\chi^2_{\text{model}} - df_{\text{model}}, 0) / \max(\chi^2_{\text{null}} - df_{\text{null}}, \chi^2_{\text{model}} - df_{\text{model}}, 0)$$

$$CFI = 1 - \max(.60 - 2, 0) / \max(300.80 - 6, .60 - 2, 0)$$

$$CFI = 1 - 0 / 294.80$$

$$CFI = 1.000$$

10. Provide a complete interpretation of the unstandardized path from IQ to GPA.

If the model is correct, then we estimate that a one unit increase in IQ will directly cause a .023 unit increase in GPA on average, holding all else constant.

11. Standardized solution:

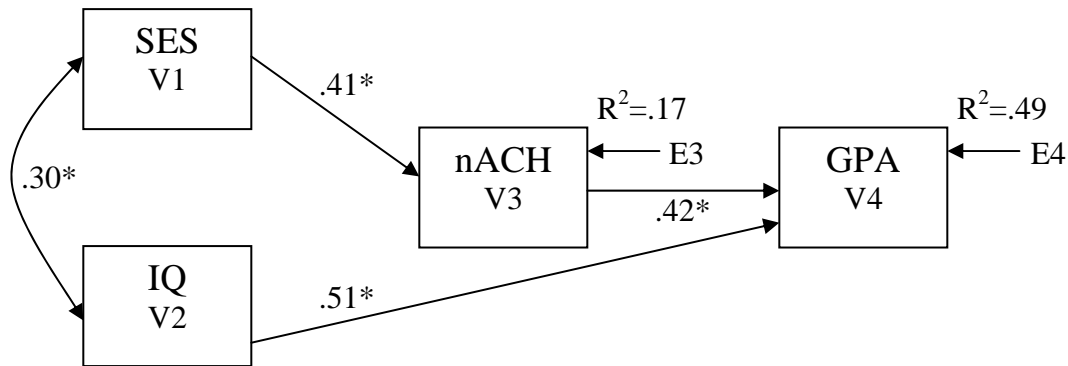

12. Provide a complete interpretation of the standardized path from IQ to GPA.

If the model is correct, then we estimate that a one standard deviation increase in IQ will directly cause a .51 standard deviation increase in GPA on average, holding all else constant.

13.

path	direct effect	indirect effect(s)	total effect
SES, IQ	----	----	----
SES, nACH	p ₃₁	----	p ₃₁
SES, GPA	----	p ₃₁ p ₄₃	p ₃₁ p ₄₃
IQ, nACH	----	----	----
IQ, GPA	p ₄₂	----	p ₄₂
nACH, GPA	p ₄₃	----	p ₄₃

DATE: 3/ 6/2009
TIME: 6:21

L I S R E L 8.80

BY

Karl G. Jöreskog & Dag Sörbom

This program is published exclusively by
Scientific Software International, Inc.
7383 N. Lincoln Avenue, Suite 100
Lincolnwood, IL 60712, U.S.A.
Phone: (800)247-6113, (847)675-0720, Fax: (847)675-2140
Copyright by Scientific Software International, Inc., 1981-2006
Use of this program is subject to the terms specified in the
Universal Copyright Convention.
Website: www.ssicentral.com

The following lines were read from file E:\EDMS722-2009\EDMS722 Assessment\EDMS722 assignments\Assignment 2 SIMPLIS\assmt1.SPL:

Path Analysis Example
OBSERVED VARIABLES
SES IQ nACH GPA
COVARIANCE MATRIX
2.250
6.840 231.040
5.658 22.374 84.640
0.346 6.065 3.220 0.490
SAMPLE SIZE is 312
RELATIONSHIPS
nACH = SES
GPA = nACH IQ
PATH DIAGRAM
END OF PROBLEM

Sample Size = 312

Path Analysis Example

Covariance Matrix

	nACH	GPA	SES	IQ
nACH	84.64			
GPA	3.22	0.49		
SES	5.66	0.35	2.25	
IQ	22.37	6.07	6.84	231.04

Path Analysis Example

Number of Iterations = 4

LISREL Estimates (Maximum Likelihood)

Structural Equations

$$\begin{aligned} \text{nACH} &= 2.51 * \text{SES}, \text{ Errorvar.} = 70.41, R^2 = 0.17 \\ &\quad (0.32) \qquad\qquad\qquad (5.66) \\ &\quad 7.90 \qquad\qquad\qquad 12.43 \end{aligned}$$

$$\begin{aligned} \text{GPA} &= 0.032 * \text{nACH} + 0.023 * \text{IQ}, \text{ Errorvar.} = 0.25, R^2 = 0.49 \\ &\quad (0.0031) \qquad (0.0019) \qquad\qquad (0.020) \\ &\quad 10.31 \qquad\quad 12.36 \qquad\quad 12.43 \end{aligned}$$

Reduced Form Equations

$$\begin{aligned} \text{nACH} &= 2.51 * \text{SES} + 0.0 * \text{IQ}, \text{ Errorvar.} = 70.41, R^2 = 0.17 \\ &\quad (0.32) \\ &\quad 7.90 \end{aligned}$$

$$\begin{aligned} \text{GPA} &= 0.080 * \text{SES} + 0.023 * \text{IQ}, \text{ Errorvar.} = 0.32, R^2 = 0.34 \\ &\quad (0.013) \qquad (0.0019) \\ &\quad 6.27 \qquad\quad 12.36 \end{aligned}$$

Covariance Matrix of Independent Variables

	SES -----	IQ -----
SES	2.25 (0.18) 12.43	
IQ	6.84 (1.35) 5.05	231.04 (18.59) 12.43

Covariance Matrix of Latent Variables

	nACH -----	GPA -----	SES -----	IQ -----
nACH	84.64			
GPA	3.10	0.48		
SES	5.66	0.34	2.25	
IQ	17.20	5.90	6.84	231.04

Goodness of Fit Statistics

Degrees of Freedom = 2
 Minimum Fit Function Chi-Square = 0.60 (P = 0.74)
 Normal Theory Weighted Least Squares Chi-Square = 0.60 (P = 0.74)
 Estimated Non-centrality Parameter (NCP) = 0.0
 90 Percent Confidence Interval for NCP = (0.0 ; 3.80)

Minimum Fit Function Value = 0.0019
 Population Discrepancy Function Value (F0) = 0.0
 90 Percent Confidence Interval for F0 = (0.0 ; 0.012)
 Root Mean Square Error of Approximation (RMSEA) = 0.0
 90 Percent Confidence Interval for RMSEA = (0.0 ; 0.078)
 P-Value for Test of Close Fit (RMSEA < 0.05) = 0.87

Expected Cross-Validation Index (ECVI) = 0.058
 90 Percent Confidence Interval for ECVI = (0.058 ; 0.071)
 ECVI for Saturated Model = 0.065

ECVI for Independence Model = 1.00

Chi-Square for Independence Model with 6 Degrees of Freedom = 300.80

Independence AIC = 308.80

Model AIC = 16.60

Saturated AIC = 20.00

Independence CAIC = 327.77

Model CAIC = 54.54

Saturated CAIC = 67.43

Normed Fit Index (NFI) = 1.00

Non-Normed Fit Index (NNFI) = 1.01

Parsimony Normed Fit Index (PNFI) = 0.33

Comparative Fit Index (CFI) = 1.00

Incremental Fit Index (IFI) = 1.00

Relative Fit Index (RFI) = 0.99

Critical N (CN) = 4791.46

Root Mean Square Residual (RMR) = 1.64

Standardized RMR = 0.015

Goodness of Fit Index (GFI) = 1.00

Adjusted Goodness of Fit Index (AGFI) = 1.00

Parsimony Goodness of Fit Index (PGFI) = 0.20

Time used: 0.010 Seconds